

2500 Series

2506A-E15TAG3

Diesel Engine – Electropak
Non-Emissions compliant

435 kWm at 1500 rpm
490 kWm at 1800 rpm



Economic Power

- Mechanically operated unit fuel injectors with advanced electronic control, combined with carefully matched turbocharging, give excellent fuel atomisation which leads to exceptional low fuel consumption.

Reliable Power

- Developed and tested using the latest engineering techniques and finite element analysis for high reliability.

- Low oil usage and low wear rates.

- High compression ratio ensures clean rapid starting in all conditions.

- Support comes from a worldwide network of 4,000 distributors and dealers.

Compact, Clean and Efficient Power

- Exceptional power to weight ratio and compact size gives optimum power density for ease of installation and more cost effective transportation.

- Designed to provide excellent service access for ease of maintenance.

The 2500 Series engine has been developed using the latest engineering techniques and builds on the strengths of the already very successful 2000 Series family and addresses today's uncompromising demands within the power generation industry. Developed from a proven heavy-duty industrial base these products offer superior performance and reliability.

The 2506A-E15TAG3 is a turbocharged and air-to-air charge-cooled, 6 cylinder diesel engine. Its premium features provide exceptional power-to-weight ratio resulting in exceptional fuel consumption.

The overall performance and reliability characteristics make this the prime choice for today's power generation industry.

This engine does not comply with harmonized international regulated emissions limits.

Engine Speed (rev/min)	Type of Operation	Typical Generator Output (Net)		Engine Power			
				Gross		Net	
		kVA	kWe	kWm	bhp	kWm	bhp
1500	Baseload power*	-	-	9	12	-	-
	Prime power	450	360	407	546	391	525
	Standby power	500	400	451	605	435	583
1800	Baseload power*	438	350	403	541	381	511
	Prime power	513	410	469	629	446	598
	Standby power	563	450	514	689	490	657

The above ratings represent the engine performance capabilities to conditions specified in ISO 8528/1, ISO 3046/1:1986, BS 5514/1. Derating may be required for conditions outside these; consult Perkins Engines Company Limited. Generator powers are typical and are based on an average alternator efficiency and a power factor (cos. θ) of 0.8. Fuel specification: BS 2869: Part 2 1998 Class A2 or ASTM D975 D2. Lubricating oil: 15W40 to API CI4.

Rating Definitions

Baseload Power: Power available for continuous full load operation. Overload of 10% permitted for 1 hour in every 12 hours operation.

Prime Power: Power available at variable load with a load factor not exceeding 80% of the prime power rating. Overload of 10% is permitted for 1 hour in every 12 hours' operation.

Standby Power: Power available in the event of a main power network failure up to a maximum of 500 hours per year of which up to 300 hours may be run continuously. Load factor may be up to 100% of standby power. No overload is permitted.

* Baseload ratings indicated are under development and will be available later.

2500 Series

2506A-E15TAG3

Standard ElectropaK Specification

Air inlet

- Mounted air filter

Fuel system

- Mechanically actuated electronically controlled unit fuel injectors with full authority electronic control
- Governing to ISO 8528-5 class G3 with isochronous capability
- Replaceable 'Ecoplus' fuel filter elements with primary filter/water separator
- Fuel cooler

Lubrication system

- Wet sump with filler and dipstick
- Full-flow replaceable 'Ecoplus' filter
- Oil cooler integral with filter header

Cooling system

- Gear-driven circulating pump
- Mounted belt-driven fan
- Radiator supplied loose incorporating air-to-air charge cooler
- System designed for ambients up to 50°C

Electrical equipment

- 24 volt starter motor and 24 volt 70 amp alternator with DC output
- ECM mounted on engine with wiring looms and sensors
- 3 level engine protection system

Flywheel and housing

- High inertia flywheel to SAE J620 size 14
- SAE 1/2 flywheel housing

Mountings

- Front engine mounting bracket

Optional Equipment

- 110 volt/240 volt immersion heater
- Additional speed sensor
- Temperature and pressure sensors for gauges
- Air filter rain hood
- Twin starters/facility for second starter
- Tool kit
- Additional manuals
- Closed circuit crankcase ventilation system

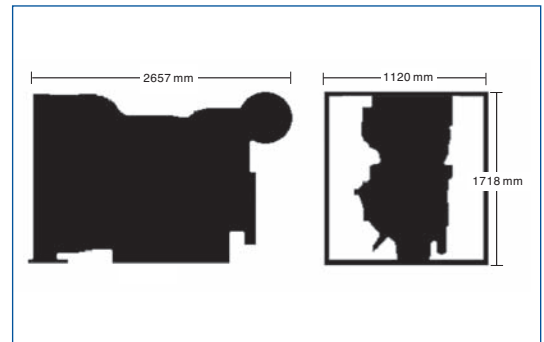

Engine Speed	Fuel Consumption			
	1500 rev/min		1800 rev/min	
	g/kWh	l/hr	g/kWh	l/hr
Standby	198	100	200	114
Prime power	199	90	196	101
75% of prime power	202	69	205	80
50% of prime power	213	48	220	57

General Data

Number of cylinders	6
Cylinder arrangement	Vertical in-line
Cycle	4 stroke
Induction system	Turbocharged and air-to-air charge cooled
Combustion system	Direct injection
Cooling system	Water-cooled
Bore and stroke	137 mm x 171 mm
Displacement	15.2 litres
Compression ratio	16:1
Direction of rotation	Anti-clockwise, viewed on flywheel
Total lubrication system capacity	62 litres
Total coolant capacity	58 litres
Dimensions	Length 2657 mm Width 1120 mm Height 1718 mm
Dry weight (ElectropaK)	1,633 kg

Final weight and dimensions will depend on completed specification



Perkins Engines Company Limited

Peterborough PE1 5NA
United Kingdom
Telephone +44 (0)1733 583000
Fax +44 (0)1733 582240
www.perkins.com



Distributed by