



2800 Series

Diesel engine - Electropak

2806C-E16TAG2

471 kWm at 1500 rpm

595 kWm at 1800 rpm



The Perkins 2800 Series is a family of well-proven 6 cylinder in-line diesel engines, designed to address today's uncompromising demands within the power generation industry with particular aim at the standby market sector. Developed from a proven heavy-duty industrial base, the engine offers superior performance and reliability.

The 2806C-E16TAG2 is a turbocharged and air-to-air charge-cooled 6-cylinder diesel engine. Its premium features provide economic and durable operation for standby duty, low gaseous emissions, overall performance and reliability.

Economic power

Mechanically operated unit fuel injectors with electronic control combined with carefully-matched turbocharging give excellent fuel atomisation and combustion with optimum economy. Low emissions result from electronic control of fuel injected.

Reliable power

Developed and tested using the latest engineering techniques and finite element analysis for high reliability. Low oil usage and low wear rates. High compression ratios also ensure clean rapid starting in all conditions.

Support comes from a worldwide network of 4000 distributors and dealers.

Compact, efficient power

Exceptional power to weight ratio and compact size give optimum power density and make installation and transportation easier and cheaper.

Designed to provide excellent service access for ease of maintenance.

Engine Speed (rev/min)	Type of Operation	Typical Generator Output (net)		Engine Power			
				Gross		Net	
		kVA	kWe	kW	bhp	kW	bhp
1500	Baseload Power *	403	323	359	481	347	465
	Prime Power	503	403	445	596	433	581
	Standby Power	553	443	483	647	471	632
1800	Baseload Power *	512	409	461	618	440	590
	Prime Power	637	509	563	755	542	727
	Standby Power	699	559	616	826	595	798

The above ratings represent the engine performance capabilities to conditions specified in ISO 8528/1, ISO 3046/1:1986, BS5514/1.

* Baseload ratings indicated are under development and will be available later

Derating may be required for conditions outside these; consult Perkins Engines Company Limited

Generator powers are typical and are based on an average alternator efficiency and a power factor (cos. θ) of 0.8.

Fuel specification: BS 2869: Part 2 1998 Class A2 or ASTM D975 D2.

Lubricating oil: 15W40 to API CG4.

Rating Definitions

Baseload Power: Power available for continuous full load operation. Overload of 10% permitted for 1 hour in every 12 hours' operation.

Prime Power: Power available at variable load with a load factor not exceeding 80% of the prime power rating. Overload of 10% is permitted for 1 hour in every 12 hours' operation.

Standby Power: Power available in the event of a main power network failure up to a maximum of 500 hours per year of which up to 300 hours may be run continuously. Load factor may be up to 100% of standby power. No overload is permitted.

2800 Series EDi 2806C-E16TAG2

Standard ElectropaK Specification

Air Inlet

Mounted air filter

Fuel System

Mechanically actuated electronically controlled unit fuel injectors with full authority electronic control
Governing to ISO8528-5 class G3 with isochronous capability
Replaceable 'ecoplus' fuel filter elements with primary filter/water separator
Fuel Cooler

Lubrication System

Wet sump with filler and dipstick
Full-flow replaceable 'ecoplus' filter
Oil cooler integral with filter header

Cooling System

Gear-driven circulating pump
Mounted belt-driven fan
Radiator supplied loose incorporating air-to-air charge cooler
System designed for ambients up to 50°C

Electrical Equipment

24 volt starter motor and 24 Volt 70 Amp alternator with DC output
ECM mounted on engine with wiring looms and sensors
3 level engine protection system

Flywheel and Housing

High inertia flywheel to SAE J620 Size 14
SAE ½ flywheel housing

Mountings

Front engine mounting bracket

Literature

User's Handbook and Parts Manual

Optional Equipment

110/240 Volt immersion heater
Additional speed sensor
Temperature and pressure sensors for gauges
Electric hours counter
Air filter rain hood
Twin starters/facility for second starter
Tool kit
Additional manuals



Perkins Engines Company Limited

Peterborough PE1 5NA
United Kingdom
Telephone +44 (0)1733 583000
Fax +44 (0)1733 582240
www.perkins.com

All information in this leaflet is substantially correct at the time of printing but may be changed subsequently by the Company

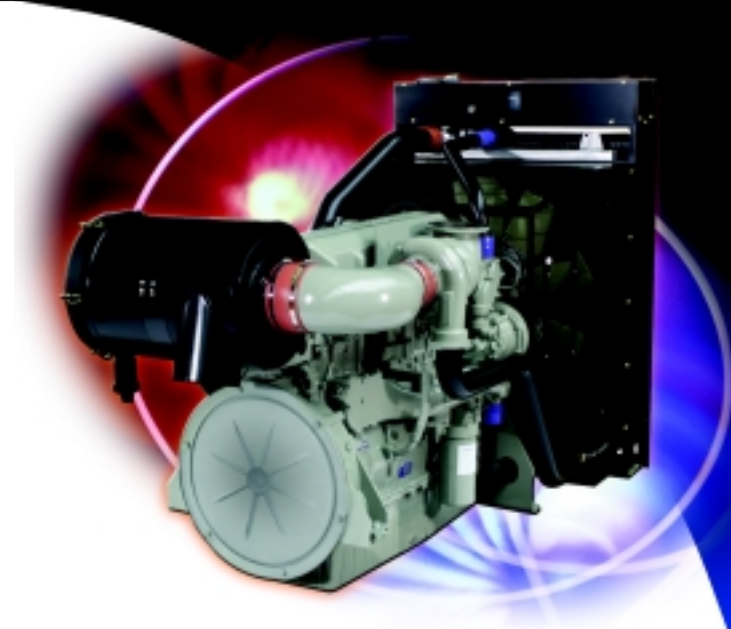

General Data

Number of Cylinders	6
Cylinder Arrangement	Vertical in-line
Cycle	4 stroke
Induction System	Turbocharged and air-to-air charge cooled
Combustion System	Direct injection
Cooling System	Water-cooled
Bore and Stroke	140 x 171 mm
Displacement	15.8 litres
Compression Ratio	15.8:1
Direction of Rotation	Anti-clockwise viewed on flywheel
Total Lubrication System Capacity	68 litres
Total Coolant Capacity	50 litres
Length	2674 mm
Width	1117 mm
Height	1722 mm
Dry Weight (Engine)	1712 kg

Engine Speed	Fuel Consumption			
	1500 rev/min		1800 rev/min	
	g/kWh	l/hr*	g/kWh	l/hr*
At Standby Power	203	113.2	211	148.4
At Prime Power	205	104.9	209	134.1
At 75% of Prime Power	207	79.2	202	96
At 50% of Prime Power	217	54.2	226	69.9

* Assumes fuel density of 0.85kg/litres

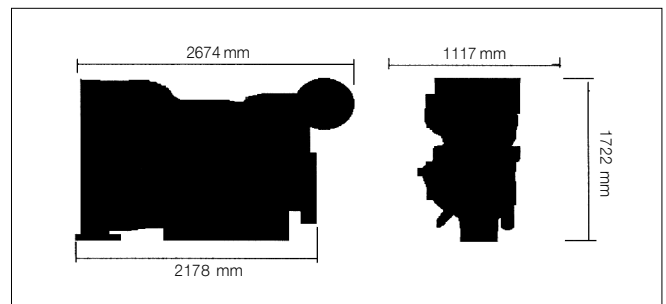

Distributed by